

# Vibration Exciter Procedure

---

*The MB Dynamics Vibration Exciter (shake table) provides sinusoidal excitation in one of two predetermined axes in the range of 100 Hz to 3000 Hz at peak acceleration. Operating below 100 Hz is possible, but at a lower acceleration level. See appendix B for a diagram of output vs. frequency. The exciter is installed next to room TB66L of the Durning Lab. It is available for use M-F 9AM-5PM. The testing equipment is available on a "first come, first serve" basis. If you want to schedule time on a machine please contact a lab technician.*

## **Purpose of This Procedure**

The purpose of this procedure is to instruct how to use the MB Dynamics vibration exciter system.

## **Precautions and Safety Requirements**

Please always wear safety glasses when running a test and keep hands away from the test fixture and exciter hardware when the test is running. If you need to immediately stop the test, press the power button on the amplifier. The parts to be vibrated should be tightly bolted to the exciter.

## **Setting up the Vibration Exciter**

1. **Understand the components.** The following figure shows the vibration exciter and identifies its primary components:

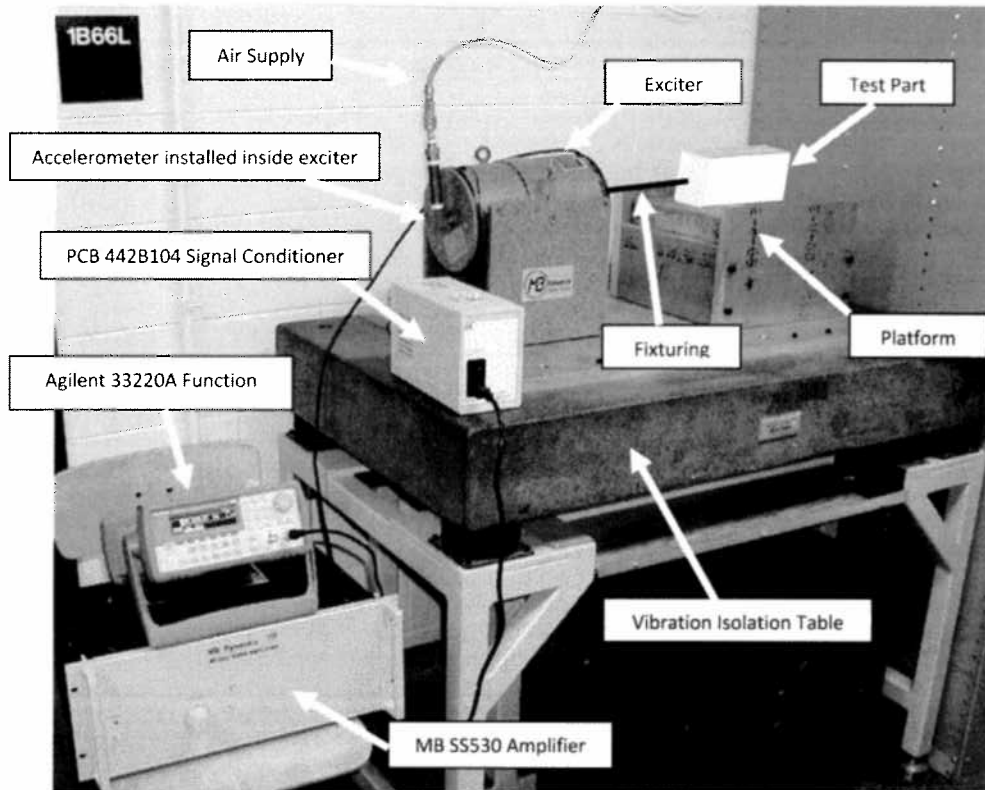

The above figure shows the major components of the MB Dynamics Vibration Exciter System. The **exciter** vibrates the work piece. The **platform** provides a smooth surface for the work piece to rest on while vibrating. The shop **air supply** line attaches to the **exciter** and keeps the magnet and voice coils cool during operation. The **vibration isolation** table isolates and damps out external vibrations from the building that may interfere with your vibration readings. The **signal conditioner** takes up to four accelerometer inputs. You will need to provide your own data acquisition system to interface with the **signal conditioner**. Data acquisition systems can be obtained from the Durning lab or the ITL. A limited supply of accelerometers is available in the Durning lab for check-out. See the appendix at the end of this document for list available accelerometers. The **function generator** allows the operator to specify the frequency, amplitude, and waveform shape for the exciter input. The **amplifier** amplifies the **function generator** output and drives the voice coil of the **exciter**. The amplitude of the **function generator** can be scaled through the amplifier. The **fixturing** connects the exciter to the **test part** to be vibrated. You will need to design and build this **fixturing**—the Durning lab does not have this because it is specific to your part. The exciter itself is instrumented with an accelerometer (not shown) that can be used for measuring the exciter output.

2. **Attach the air supply.** The exciter system may be operated up to 50% of its rated force output (50 pounds force for this unit—see Figure 6) using natural convection cooling. When operating above this level, forced air cooling is required. To use forced air

cooling, make sure the air is attached to the exciter air supply port. The air hose is hanging from the ceiling above the system. See figure below.

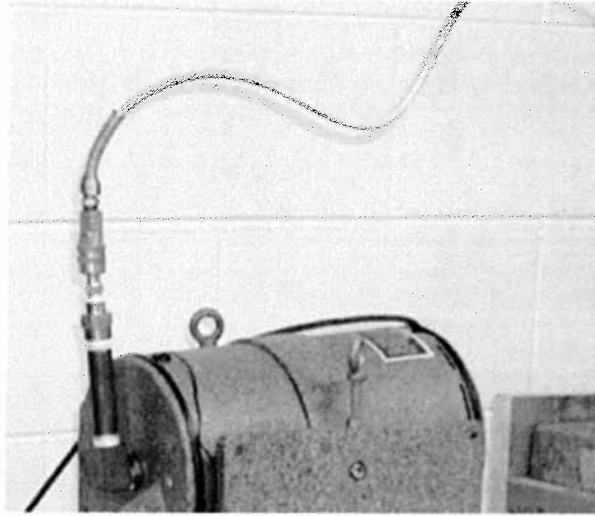

Figure 1 - Air supply attached to the exciter.

### 3. Attach the electronics.

Connect the output of the function generator to channel 1 on the back of the amplifier as shown in the following wiring diagram and figure. Plug the exciter power cable into the channel 1 output port of the amplifier.

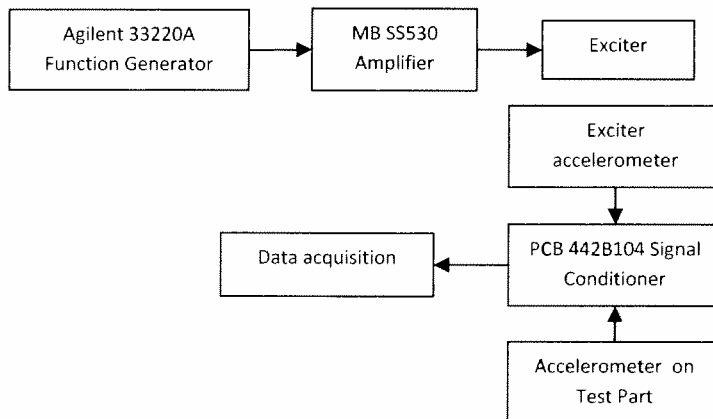

Figure 2 - Wiring Diagram

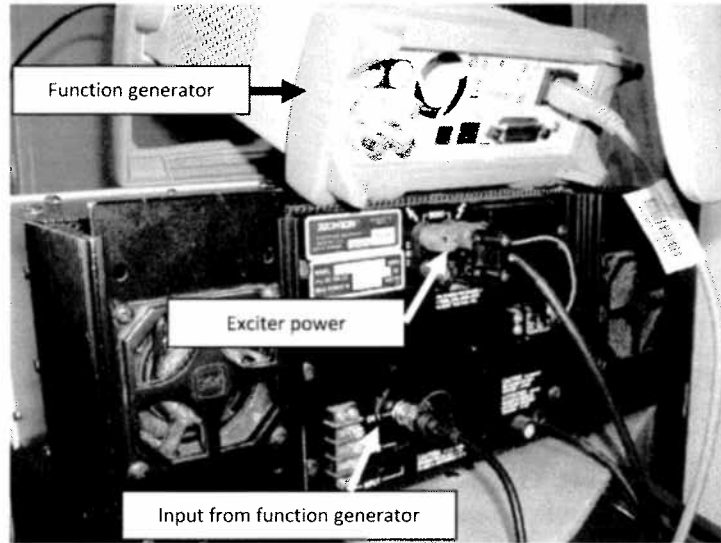

Figure 3 - Electronics setup

#### 4. Attach the work piece to the exciter

The face of the exciter has a bolt hole pattern for attaching the work piece fixturing. The hole pattern is 6 x 10-32 thread on a 2.25" diameter. The work piece can be mounted in either a vertical or horizontal position (see Figure 4 and Figure 5).

- a. **Vertical mounting:** To orient the exciter in the vertical position, loosen the orientation bolt, rotate the exciter 90 degrees, and then tighten the orientation bolt. In this orientation, the exciting force is to be applied to the test structure from below. Not shown is the test fixturing required to actuate the test part in this orientation. Caution should be used to ensure that platforms and other test fixturing used to support the work piece are capable of adequately reacting to the forces generated by the combined moving masses of the armature and test article.

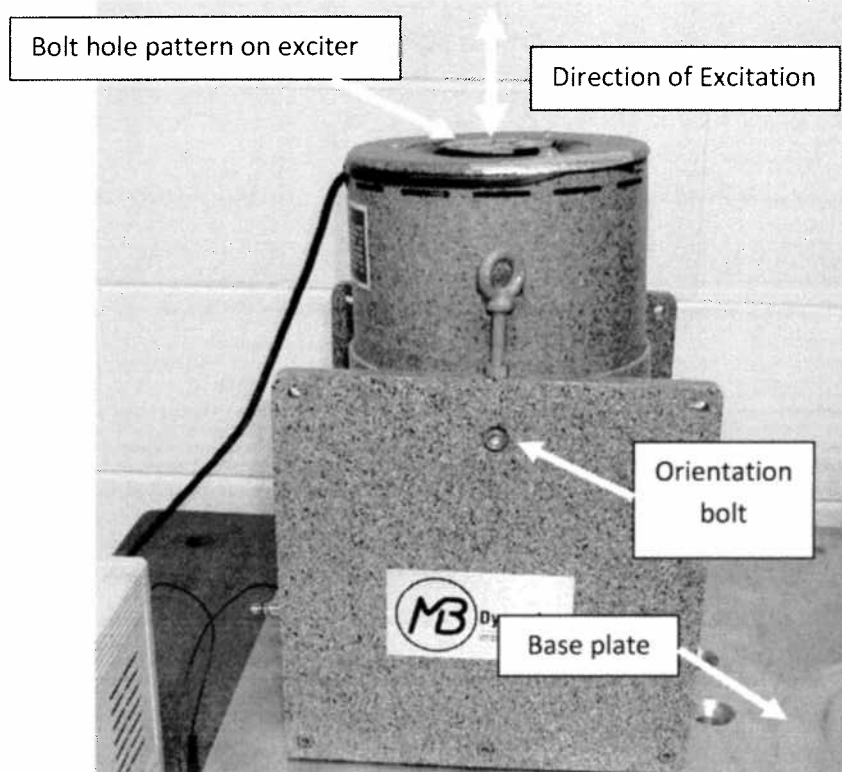

Figure 4 - Exciter in vertical orientation

- b. **Horizontal mounting:** When mounted horizontally (see figure below), the lateral forces generated by the exciter are transferred to the base plate on which the equipment is mounted. Prior to use, inspect the mounting bolts to ensure that every mounting bolt is tight.

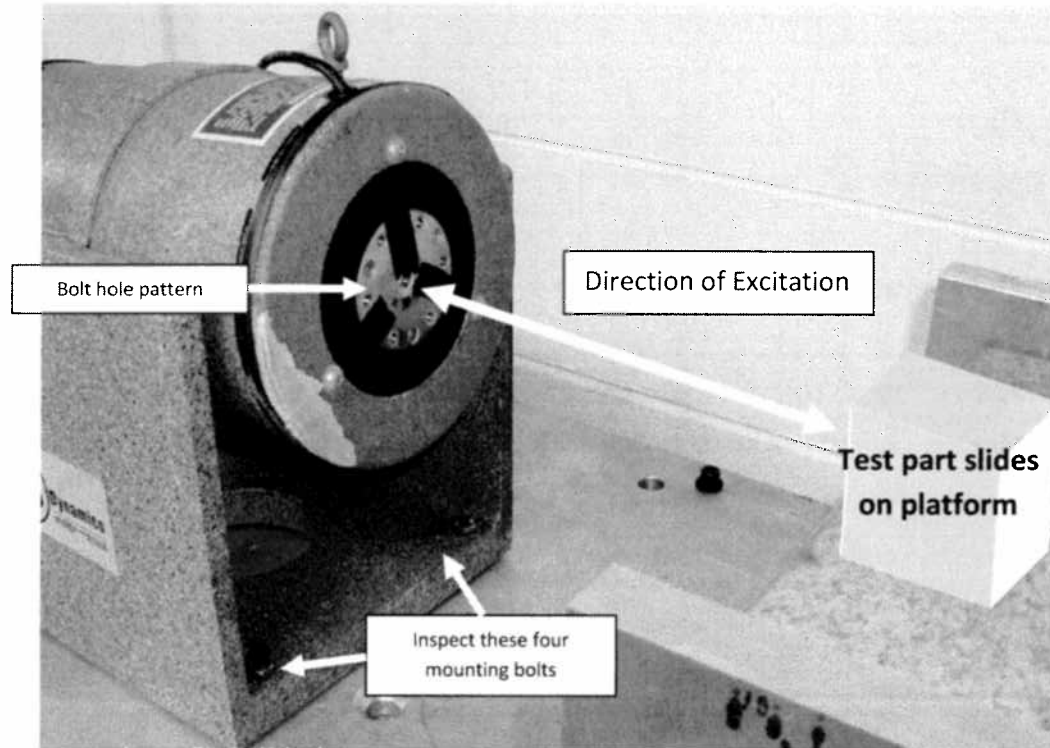

Figure 5 – Horizontal position and work piece attachment

## Design the experiment

First, design all the test fixturing needed to interface the work piece to the exciter. It is important to consider all masses, including measurement equipment (like accelerometers) that may exert a load on the exciter. Next, calculate the maximum attainable shaker acceleration. This value is dependent upon total load. The total load is the sum of the weight of the moving element, the weight of the work piece, and the weight of any fixturing, therefore, the maximum attainable shaker acceleration is found by the following equation:

$$G_{max} = \frac{F_R}{W_{ME} + W_{TA} + W_F + W_A} \quad (1)$$

Where:

$G_{max}$  = Maximum allowable table acceleration, in g's

$F_R$  = Rated force (in this case, 100 pounds peak)

$W_{ME}$  = Weight of the moving element, in pounds (in this case, 1lb)

$W_{TA}$  = Weight of the test article, in pounds

$W_F$  = Total weight, in pounds, of fixturing and bolts

$W_A$  = Total weight, in pounds, of instrumentation (e. g. accelerometers)

**You must be careful to not exceed the maximum acceleration of the exciter or you will damage the equipment.** You must instrument your test setup with accelerometers so that you know the acceleration during the test. As mentioned, there is an accelerometer mounted on the voice coil, inside the exciter. An external accelerometer of your choice is typically mounted on the test specimen. During your test, verify that the output from the exciter accelerometer does not exceed the max allowed acceleration as shown in the following figure.

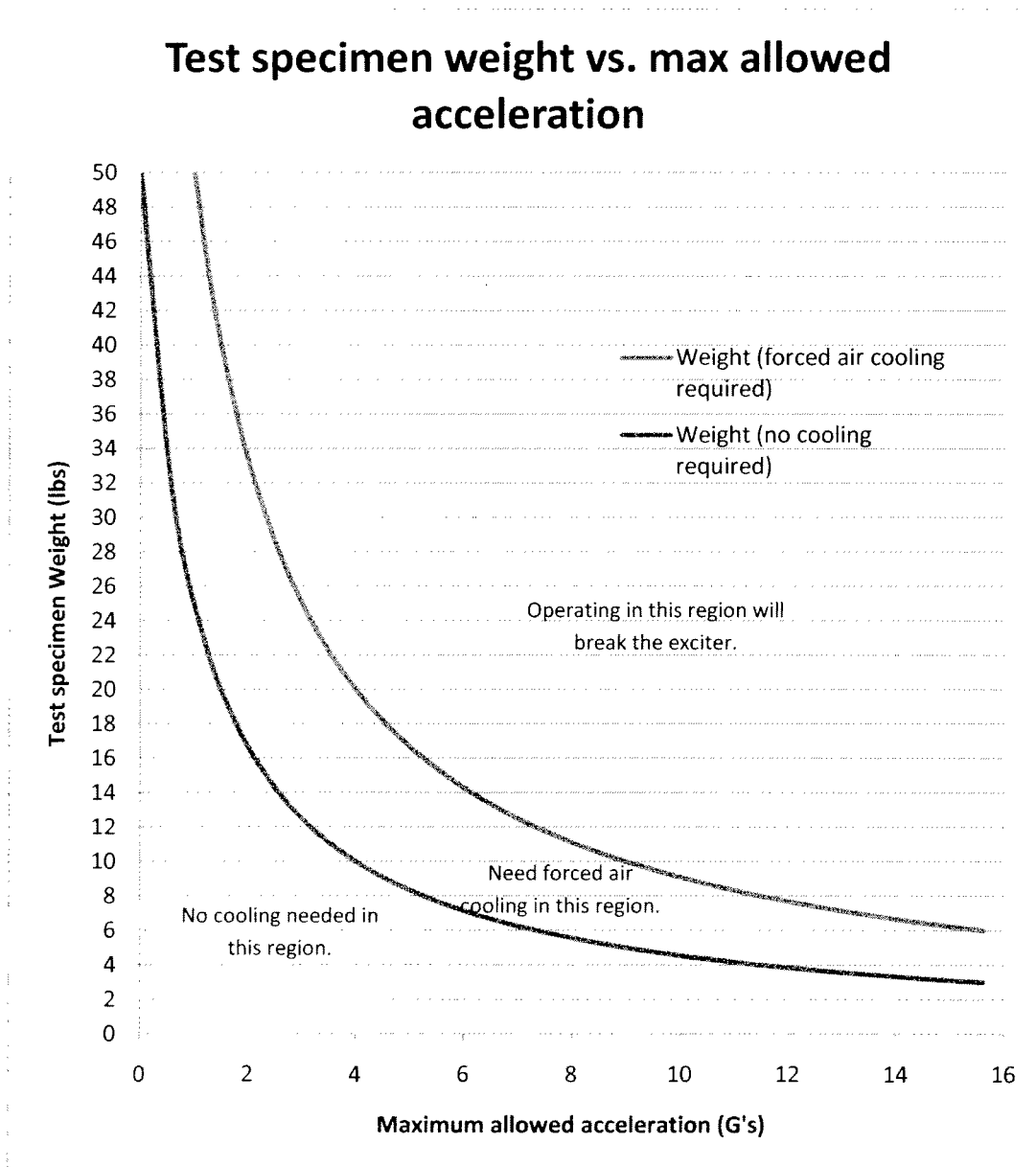

Figure 5 - Maximum allowed acceleration vs. test specimen weight

**Example:** Suppose our goal is to determine the frequency response of a hard drive to 200 Hz horizontal input. Figure 5 shows a typical setup for this kind of test. The test

part (hard drive in this case) rests on the platform. We will need to design fixturing to attach the test part to the bolt hole pattern on the exciter.

In this case, the output will be acquired from an accelerometer placed on the hard drive to measure horizontal acceleration and the input will be the acquired from the accelerometer which is integrated into the exciter voice coil.

The first step is to determine the maximum acceleration from equation 1 above. For our example we will use 2lbs for the weight of the hard drive, .5 pounds for the weight of the fixturing and bolts used to attach the hard drive to the exciter bolt hole pattern, and .01lbs for the weight of the accelerometers and cabling:

$$W_{TA} = 2\text{lb}$$

$$W_F = .5\text{lb}$$

$$W_A = .01\text{lb}$$

The following values are properties of our exciter:

$$F_R = 100\text{lbf}$$

$$W_{ME} = 1\text{lb}$$

Based on these values, the maximum allowable acceleration for this experiment is 28.49g's. If we exceed this value, we will break the exciter so to be safe, our experiment should only go to about half this value, or 14g's. Also note from Figure 6 that we do not need forced air cooling at 14g's for this test setup.

Note that our maximum amplitude may be limited by the allowable acceleration so if your experiment is amplitude controlled, you will need to understand the relationship between amplitude and acceleration for your particular driving frequency. This relationship is:

$$D_0 = \frac{A_{max}}{(2 \pi f)^2}$$

Where:

$D_0$  = Maximum allowable amplitude

$A_{max}$  = Max allowable acceleration (convert to appropriate units from  $G_{max}$  above).

$f$  = frequency (Hz)

Final note: the frequency response of our hard drive to one frequency is only marginally useful. Of much greater interest would be the frequency response to a band of frequency inputs. To accomplish this we need to perform something called a "swept sine" input. The Agilent 33220A Function generator is not capable of performing this function. To do this, you will need to check out a programmable analog output device from the ITLL.



## Run the experiment

Prior to turning on the equipment, make sure the amplitude adjust knob on the amplifier is turned fully counterclockwise. This ensures that you will not accidentally apply full gain to the function generator signal exciter. Turn on the function generator and then press the power button on the amplifier to turn it on (see below). Adjust the function generator to generate the desired output signal and then press the "Output" button on the function generator. At this point, the exciter should be actuating the work piece.

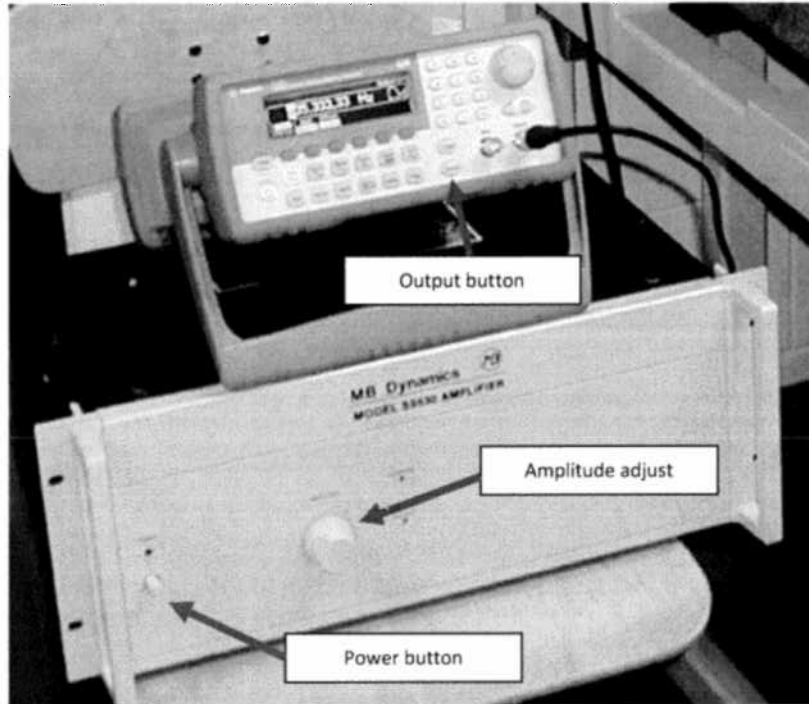

Figure 7 - Power on the equipment

### Appendix A – Accelerometers available in the Durning lab.

The following table lists the accelerometers available in the Durning lab. All are from **PCB Piezotronics**.

Type	Model	Serial Number	Sensitivity
Shear	352A25	78573	2.595 mV/g
Shear	352B01	77818	1.101 mV/g
Shear	UT356A15	19279	105.7 mV/g
Shear	UT356A15	19438	91.6 mV/g
Shear	U352B10	28476	9.77 mV/g
Shear	356A02	C12733	9.84 mV/g

### Appendix B – PM100 Electrodynamic Vibration Exciter User's Manual